

BEL 150 - 2000



Hot water storage tank

BEL 150 - 2000

Application

The hot water storage tank with flange connection can be used as a charging tank for various heating sources.

Corrosion protection for parts with drinking water contact

Enamelled as per DIN 4753. A magnesium anode offers additional corrosion protection.

External corrosion protection

Up to 500 l protective enamelled layers and foam encased

800 to 2,000 l powder-coated

Heat insulation

Type 150-600: 50 mm PU rigid foam insulation with soft sleeve

Type 800-1000: 95 mm PU rigid foam half-shell with soft sleeve

Type 1500-2000: 85 mm PU rigid foam half-shell with soft sleeve

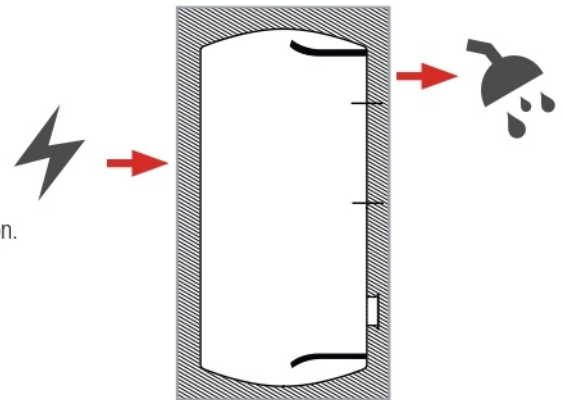

Model overview BEL 150 - 2000

Type	Article no.	Volume	Height with insulation	Tilt height	Installation diameter	Weight (empty)	Efficiency class
Unit	[-]	[l]	[mm]	[mm]	[mm]	[kg]	[-]
BEL 150	STD0150BEL	156	970	1150	610	57	B
BEL 200	STD0200BEL	224	1350	1485	610	67	C
BEL 300	STD0300BEL	285	1670	1780	610	89	C
BEL 400	STD0400BEL	415	1500	1685	760	122	C
BEL 500	STD0500BEL	496	1740	1900	760	139	C
BEL 800	STD0800BEL	805	1990	2020	790	251	C
BEL 1000	STD1000BEL	910	2190	2220	790	276	C
BEL 1500	STD1500BEL	1508	2120	2150	1000	320	C
BEL 2000	STD2000BEL	1936	2350	2400	1100	340	C

Hot water storage tank

Technical specifications BEL 150 - 2000

Type	Unit	BEL 150	BEL 200	BEL 300	BEL 400	BEL 500	BEL 800	BEL 1000	BEL 1500	BEL 2000	
Article no.	[-]	STD0150BEL STD0150BEL.H	STD0200BEL STD0200BEL.H	STD0300BEL STD0300BEL.H	STD0400BEL STD0400BEL.H	STD0500BEL STD0500BEL.H	STD0800BEL	STD1000BEL	STD1500BEL	STD2000BEL	
Volume	[l]	156	224	285	415	496	805	910	1508	1936	
Height with insulation	[mm]	970	1350	1670	1500	1740	1990	2190	2120	2350	
Diameter with insulation	[mm]	610	610	610	760	760	1000	1000	1200	1200	
Diameter without insulation	[mm]	600	500	500	650	650	790	790	1000	1100	
Installation diameter	[mm]	610	610	610	760	760	790	790	1000	1100	
Tilt height	[mm]	1150	1485	1780	1685	1900	2020	2220	2150	2400	
Installation diameter	[mm]	57	67	89	122	139	251	276	320	340	
Weight (empty)	[kg]	10	10	10	10	10	10	10	6	6	
Max. operating pressure hot drinking water side	[bar]	15	15	15	15	15	15	15	9	9	
Test pressure hot drinking water side	[bar]	95	95	95	95	95	95	95	95	95	
Max. operating temperature hot drinking water side	[°C]	50	50	50	50	50	95	95	85	85	
Insulation thickness	[mm]	500	500	500	650	650	800	800	1000	1100	
Max. installation length EHP	[mm]	2	2	2,5	4	4	7,5	7,5	12	15	
Max. output EHP	[kW]	1,21	1,60	1,90	2,40	2,60	3,10	3,40	4,10	4,50	
On-demand heat overhead	[kWh/d]	50	68	80	101	107	129	141	171	185	
Holding losses	[W]	B	C	C	C	C	C	C	C	C	
Efficiency class	[-]	B	C	C	C	C	C	C	C	C	
Insulation material	[-]	PU rigid foam ($\lambda=0.024$ W/mK)					PU rigid foam shell ($\lambda=0.024$ W/mK)				
Corrosion protection	[-]	Enamelled as per DIN 4753, magnesium anode									

Connections and dimensions BEL 150 - 2000

Connections		Unit	BEL 150	BEL 200	BEL 300	BEL 400	BEL 500	BEL 800	BEL 1000	BEL 1500	BEL 2000
FO	Sensor	[mm]	970 ½" IT	1350 ½" IT	1670 ½" IT	1500 ½" IT	1740 ½" IT	1940 ½" IT	2140 ½" IT	2070 ½" IT	2300 ½" IT
ENT	Ventilation	[mm]	-	-	-	-	-	1940 1¼" IT	2140 1¼" IT	2070 1¼" IT	2300 1¼" IT
AN	Anode	[mm]	970 1¼" IT	1350 1¼" IT	1670 1¼" IT	1500 1¼" IT	1740 1¼" IT	1940 1¼" IT	2140 1¼" IT	2070 1¼" IT	2300 1¼" IT
F/TH	Sensor/Thermometer	[mm]	760 ½" IT	1140 ½" IT	1425 ½" IT	1250 ½" IT	1490 ½" IT	1650 ½" IT	1850 ½" IT	1750 ½" IT	1950 ½" IT
EHP	Electric heating cartridge	[mm]	-	730 1½" IT	970 1½" IT	855 1½" IT	990 1½" IT	1225 Ø180/120	1375 Ø180/120	1300 Ø180	1500 Ø180/120
FL	Flange	[mm]	285 Ø180/120	285 Ø180/120	285 Ø180/120	310 Ø180/120	310 Ø180/120	420 Ø290/230	420 Ø290/230	470 Ø290	490 Ø290/220
WW	Hot water	[mm]	970 1¼" IT	1350 1¼" IT	1670 1¼" IT	1500 1¼" IT	1740 1¼" IT	1765 2" IT	1965 2" IT	1850 2" IT	2065 2" IT
Z	Circulation	[mm]	760 ½" IT	1000 ½" IT	1250 ½" IT	1115 ½" IT	1270 ½" IT	1400 1" IT	1600 1" IT	1450 1" IT	1650 1" IT
F2	Sensor 2	[mm]	390 ½" IT	390 ½" IT	390 ½" IT	450 ½" IT	450 ½" IT	650 ½" IT	650 ½" IT	850 ½" IT	900 ½" IT
KW	Cold water	[mm]	135 1¼" IT	135 1¼" IT	135 1¼" IT	145 1¼" IT	145 1¼" IT	175 2" IT	175 2" IT	220 2" IT	235 2" IT
M1	Sleeve 1	[mm]	-	-	-	-	-	900 2" IT	1000 2" IT	1050 2" IT	1200 2" IT
F1	Sensor 1	[mm]	-	-	-	-	-	1050 ½" IT	1150 ½" IT	1150 ½" IT	1350 ½" IT
M2	Sleeve 2	[mm]	-	-	-	-	-	1525 1¼" IT	1725 1¼" IT	1650 2" IT	1800 2" IT

BEL 150 - 500

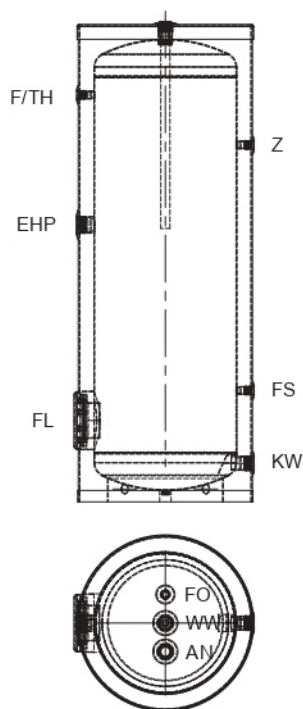

BEL 800 - 2000

